



Inkjet Printer

F540/560/560Plus Series

Operation Manual

Content

1. Safety Guidelines	1
1.1 safety warning	1
1.2 Safety prevention	1
1.3 Use	1
1.4 Handling	2
1.5 Responsibility	2
2. Introduction	3
2.1 Appearance overview	3
2.2 Control Panel	3
2.3 Printhead	4
2.4 Ink Core	4
2.5 Main Screen	5
2.6 Menu Analysis	6
2.6.1 PRINT DATA	6
2.6.2 USER FIELD	6
2.6.3 PRINT SET	7
2.6.4 INK SYSTEM	8
2.6.5 MACHINE SET	9
2.6.6 F4 Password	10
2.6.7 W) User Defined	10
2.6.8 Photocell 1 Set	11
2.6.9 Photocell 2 Set	11
2.7 Specifications	12
3. Printer Operation	13
3.1 Commission (For F540/560/560Plus)	13
3.2 Start The Printer	14
3.2.1 Start Jet	14

Content

3.2.2 Inkjet Observation -----	15
3.2.3 Drops Observation -----	16
3.3 Stop Jet-----	17
3.3.1 Stop Jet and Clean-----	17
3.3.2 Stop and Clean (Power off during use of the printer)-----	17
3.3.3 Stop and Clean (long-term stop of use)-----	17
3.4 Create Message -----	18
3.4.1 Create a Sample Message-----	18
3.5 Create/Edit User Field -----	20
3.5.1 Time User Field -----	20
3.5.2 Additional remarks for time user field-----	21
3.5.3 Barcode User Field-----	22
3.5.4 Additional remarks for Barcode User Field-----	23
3.5.5 Counter User Field -----	24
3.5.6 Instructions for Items in the Counter-----	25
3.5.7 Logo User Field -----	26
3.5.8 Code User Field-----	28
3.5.9 External data User Field -----	29
3.6 Message Parameters -----	30
3.6.1 Modify message parameters and contents -----	30
3.7 Print Mode Setting -----	31
3.7.1 Single Printing Mode-----	31
3.7.2 Continuous Printing Mode-----	32
3.7.3 Measure mode -----	33
3.7.4 Traverse Printing Mode -----	34
3.7.5 Repeat Printing Mode -----	35

4. Maintenance -----36

4.1 Diagnostic Screen -----	36
-----------------------------	----

Content

4.2 Failure and warning icons-----	37
4.2.1 Failure icons -----	37
4.2.2 Warning icons -----	38
4.3 Troubleshooting -----	39
4.4 Wash Nozzle -----	40
4.5 Ink Jet Alignment-----	40
4.6 Drain(For F560Plus)-----	41
4.7 Clean Ink System -----	41
4.8 Sensor and Encoder Wiring Diagram -----	42
4.8.1 Sensor Diagram-----	42
4.8.2 Encoder Diagram-----	42
4.9 Printer Stander-----	43

1. Safety Guidelines

1.1 safety warning

- Maintenance of this equipment must be performed by a maintenance professional.
- When the printer is connected to the power supply and related circuits, a lethal voltage is generated. Non-professionals cannot open the circuit compartment, and cannot check and repair the circuit system.
- The consumables used in the printer may be flammable liquids. The use of consumables must not only follow the Material Safety Data Sheet (MSDS) instructions, but also the printer must be regularly inspected and maintained to minimize safety hazards. (Note: The printer has an alarm function that has been sent for maintenance time. Please pay attention to whether this function is normal. If there is an alarm when the printer maintenance time has expired, please notify the service engineer in time.)

1.2 Safety prevention

- The installation of the printer should be stable and well grounded .
- The printer must be installed in a ventilated place, away from heat, fire and static electricity. No smoking near the printer.
- The container lid of the ink, solvent and cleaning agent used in the printer should be tightly closed and stored in a ventilated environment away from the printer.
- The printer should be kept clean, because the consumables used may be flammable liquids, and the ink can burn after drying.
- Place a carbon dioxide dry powder fire extinguisher near the printer.

1.3 Use

- The printer is a non-contact inkjet device and is not suitable for all occasions (such as explosive atmospheres). It should be used in accordance with safety guidelines and provide a suitable working environment. Otherwise, the consequences will be borne by the user.

- It is recommended to use the original consumables (including inks, solvents, cleaning agents, maintenance products, etc.) of the printer. You must obtain the Material Safety Data Sheet (MSDS) from the dealer and read and follow them carefully. Otherwise the consequences will be borne by the user.
- In operation, wear anti-ink gloves and safety glasses for those who may touch the consumables.

1.4 Handling

- For machines with ink and solvent in the machine, non-vertical handling is prohibited. If the printer cannot be kept in a vertical state, the ink and solvent should be completely drain out before handling.

1.5 Responsibility

- Our company is not responsible for any consequences resulting from violations of safety instructions, safety requirements and violations of basic safety practices when using and maintaining the printer.

2. Introduction

2.1 Appearance overview

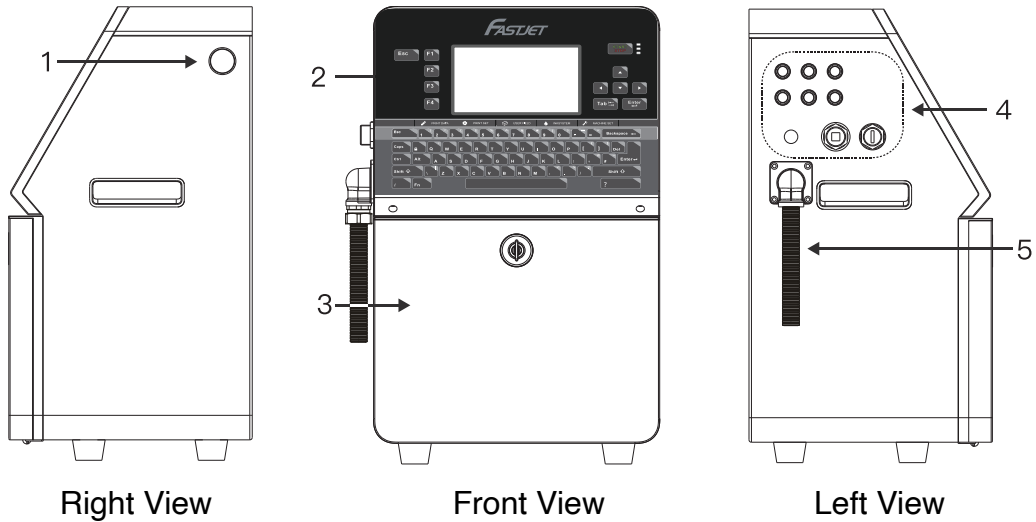

Introduction:

1. Power button
2. Upper: Electronics Compartment 、 Control Panel
3. Lower: Ink Compartment
4. Connector Panel
5. Umbilical

2.2 Control Panel

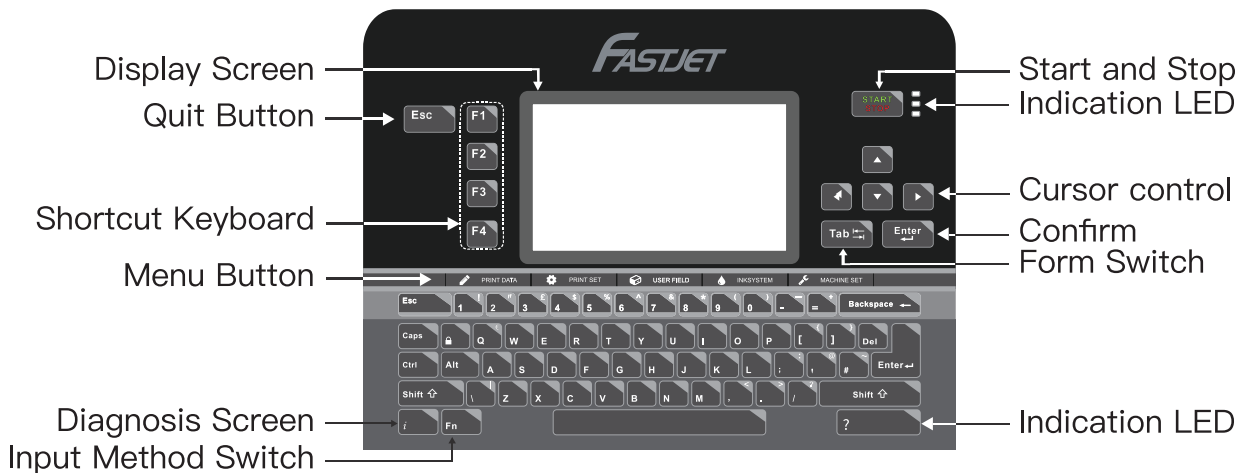

2.3 Printhead

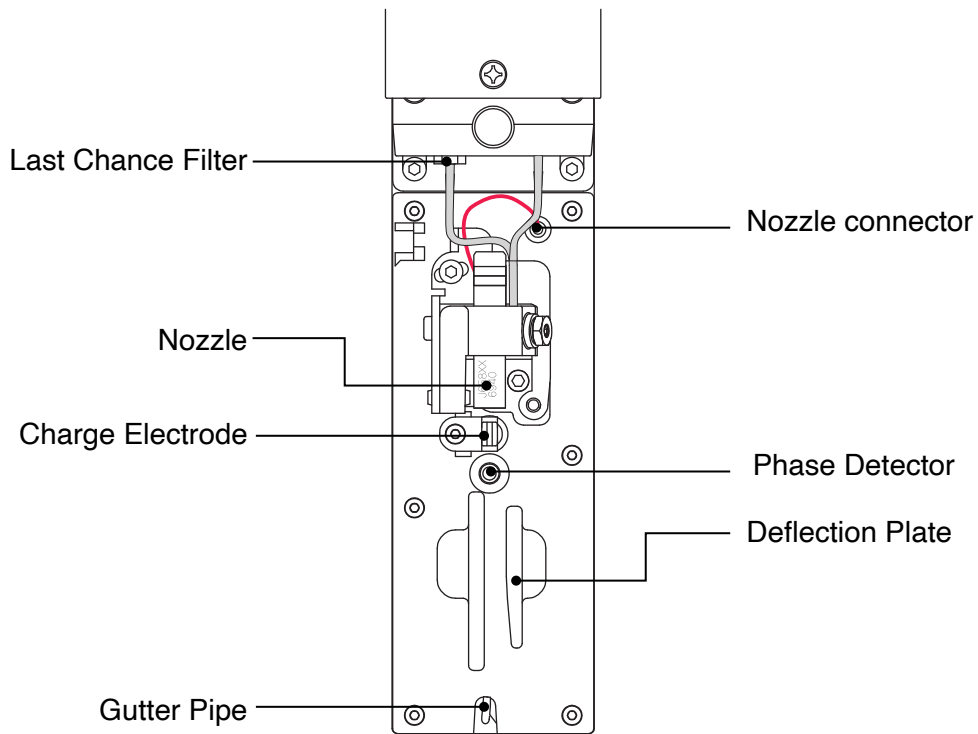

2.4 Ink Core

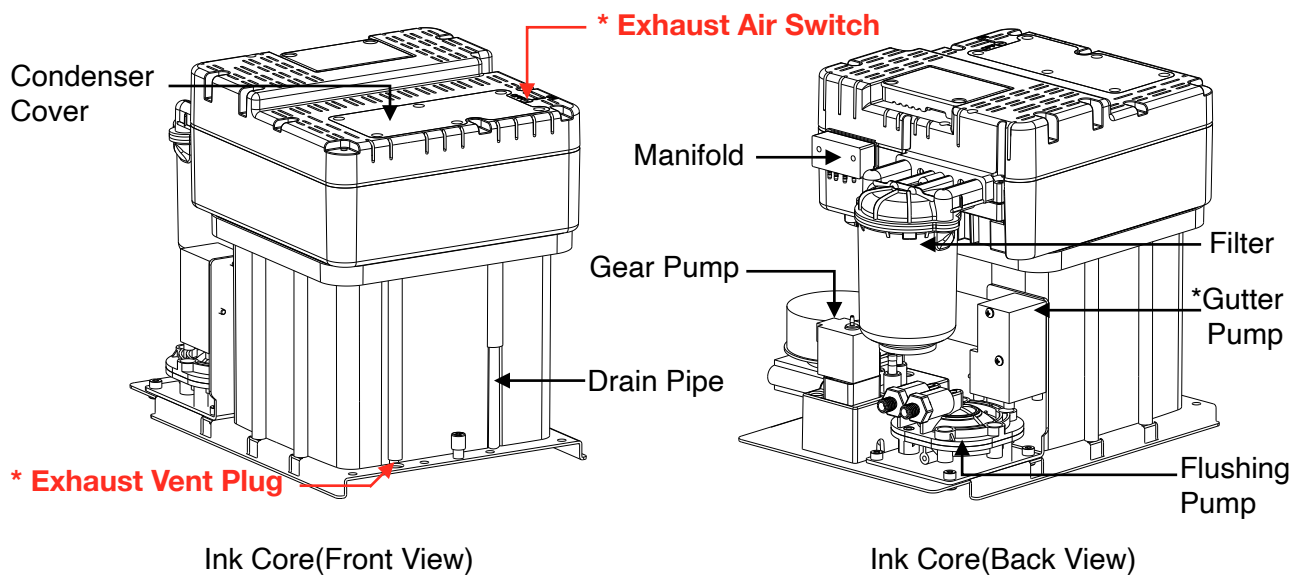

* Please remove the exhaust vent plug and turn on exhaust air switch before use.

* It's Gutter Pump for F560Plus
* It's Addition Pump for F540/F560

2.5 Main Screen

The main screen is the default screen after the printer powered on:

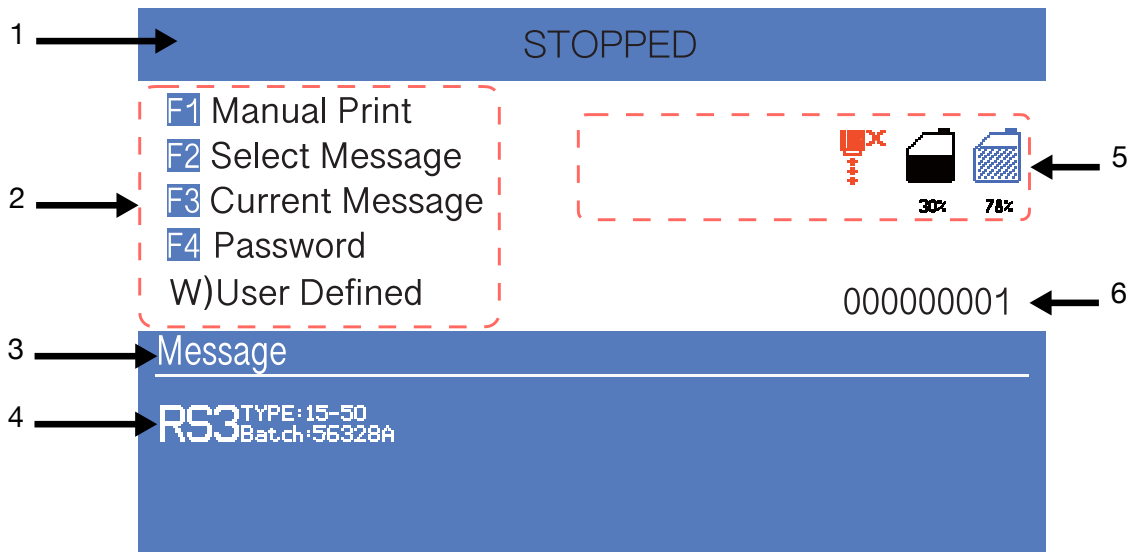

Instructions:

1. The current status description area of the device;
2. A shortcut function keypad includes an user-defined function;
3. The name of the current message ;
4. The content of the current message, it's a WYSIWYG message viewer, the content of which is consistent with the content printed by the printer;
5. The printer icon display area contains icons such as consumables, equipment status, warnings and faults;
6. The counter of the cumulative number of prints can be reset;

2.6 Menu Analysis

2.6.1 PRINT DATA

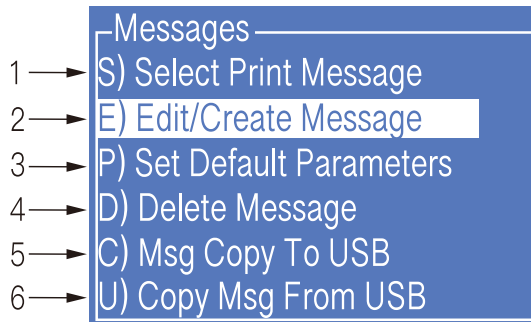

1. It is used to select and recall the stored messages , which is equivalent to the “F2 Select Message” on the main screen.
2. Used to create and edit saved messages.
3. Used to set the default message parameters.
4. It is used to delete the messages stored in the printer.
5. It is used to copy the messages in the printer to the USB storage device.
6. It is used to copy the messages in the USB storage device into the printer.

2.6.2 USER FIELD



1. Used to create and edit saved user fields.
2. Used to delete user fields that have been stored in the printer.
3. Used to transfer the custom pattern in the printer to the USB storage device.
4. Used to copy the picture files (BMP monochrome) in the USB storage device into the printer.
5. It is used to set the date and time code. For example, if January is printed as Jan, etc., in the time user field, the date and time code can be referenced by referring to a specific letter, RR can refer to the year code, and SSS can refer to the month code, TT can reference the day code, UU can reference the hour code, VV can reference the minute code, some models do not include this function.

2.6.3 PRINT SET

	Print	
1 →	E) Print Enable	Enable
2 →	Q) Print Quality	Standard
3 →	P) F1 Manual Print	Disable
4 →	1) Photocell 1 Set	
5 →	2) Photocell 2 Set	
6 →	S) Shaft Encoder	Internal
7 →	R) Reset Message Counter	
8 →	N) Reset Product Counter	0
9 →	M) Print Mode	Single
10 →	C) Continuous Print CONFIG	
11 →	T) Repeat Print CONFIG	
12 →	I) Traverse Print CONFIG	
13 →	D) Speed Ratio	

- Used to enable or disable the printing function. if set to "Disable", the printer will disable the printing function and prompt "High voltage not activated" in the status bar.
- It is used to select the printing quality, standard and high quality 01~15. The higher the high quality selection, the better the printing quality will be, but the slower the printing speed will be.
- It is used to set whether the main screen "F1 Manual Start/Stop Printing" is effective. If you need to use an external sensor such as an electric eye, you need to set this option to "Disable".
- Photocell 1 Set, refer to 2.6.8 Photocell 1 setting submenu.
- Photocell 2 Set, refer to 2.6.9 Photocell 2 setting submenu.
- Set the encoder mode, you can set "internal", "external". When set to "External", it is effective to use an encoder.
- Used to reset the counter used in the current message to any value within the counter range.
- The product counter on the main screen can be reset to any value.
- It is used to set the printing mode of the printer, which can be set to "Single", "Repeat", "Continuous" and "Traverse".
- When the print mode is set to "Continuous", use this menu to set "Internal Interval" (valid when the shaft encoder is internal), "External Interval" (valid when the shaft encoder is external) and "Measure" related options.
- When the print mode is set to "Repeat", use this menu to set the "Print times" to control the print times per trigger.
- When the print mode is set to "Traverse", use this menu to set the options for traverse printing;
- It is used to set the ratio between the actual effective value and the set value of the message width, delay and message interval. Default value is 1.

2.6.4 INK SYSTEM

	System	
1 →	W) Flush Nozzle	
2 →	F) Wash Nozzle	
3 →	D) Debug	
4 →	U) Umbilical Purge	
5 →	S) Quick Start Jet	
6 →	T) Quick Stop Jet	
7 →	I) Set Ink Type	B600
8 →	V) VMS Calibration	
9 →	Z) Pressure Zero Offset	
10 →	C) Clean Ink System	
11 →	E) Exhaust Air	
12 →	B) Positive Air Pump	Close
* 13 →	R) Drain	
14 →	N) System Clean	
* 15 →	A) Fill Mixer	

1. Flushing the nozzle blockage automatically.
2. After performing , open the printhead cover and use cleaning agent to clean the nozzle manually. Refer to 4.4 Nozzle Cleaning for details.
3. It is used to control the pump, valve and other parts separately.
4. Used for cleaning umbilical , only for commissioning engineers to use when debugging.
5. It is used to quickly start the jet.
6. For quick stop inkjet without auto cleaning.
7. For setting the ink type, built-in B600, 601, A630, 680, 619, 669, 2630, 2631 and 630.
8. Used to set the ink viscosity, manual / auto optional;
9. Used to calibrate the standard reference pressure;
10. For the entire ink system cleaning, follow the on-screen instructions, refer to 4.7
System Cleaning;
11. Used to exhaust the air, usually for commissioning.
12. Open/Close the positive air to the printhead.
13. It is used to fill the mixer tank with ink to the OK level. It is used when the machine is first time use. (F540/F560 without this option).
14. It is used to clean the umbilical. To perform this procedure, the nozzle connecting pipe should be shorted.
15. Use for fill ink for F560Plus, (F540/F560 without this option).

2.6.5 MACHINE SET

	Configuration	
1 →	T) Charge Fault Shutdown	Enable
2 →	G) Gutter Fault Shutdown	Enable
3 →	M) Modulation Set Level	
4 →	C) Charge Value	150
5 →	P) Running Pressure	350
6 →	H) Heater Point	42
7 →	A) Phase Charge	120
8 →	O) Phase Offset Set	9
9 →	I) Software No.	
10 →	W) User Defined	
11 →	B) Keyboard Buzzer	Enable
12 →	T) Set Time/Date	
13 →	E) EHT Leak Value	200
14 →	F) EHT Range Set	
15 →	U) Gutter Mode	Continuous
16 →	S) Serial Port Config	
17 →	J) Ethernet Interface	
18 →	L) Set Language	
19 →	N) Maintain Time	
20 →	D) Backlight Saver	Enable
21 →	K) EHT Grade	High

1. Used to disable the automatic shutdown caused by charge fault.
2. Used to disable the automatic shutdown caused by the gutter fault.
3. used to set the modulation value, manual/auto optional, auto mode only takes effect during startup.
4. Used to set the charge value.
5. Used to set the running pressure.
6. Used to set the heater target temperature.
7. Used to set the phase charge value.
8. Used to set the phase offset value.
9. Used to check the current software information.
10. Used to define the shortcut function on main screen.
11. Used to enable /disable the keyboard buzzer.
12. Used to set the system time and date;
13. Used to set the extra high tension leakage alarm value.
14. Used to set the output range of the 7KV extra high tension.
15. Used to change the gutter mode.
16. Used for serial port configuration.
17. Used for Ethernet configuration.
18. Used to set the printer language.
19. Used to view equipment maintenance time.
20. Turn off the backlight protection, the screen is always bright, will shorten the screen life
21. When the EHT Grade is High, the detection sensitivity is enhanced; When it is Low, the detection sensitivity is reduced, and relevant safety prompts will pop up when the power is turned on.

2.6.6 F4 Password



Only "Enter Password" menu is displayed before the password is entered.

1. Used to enter password;
2. Used to exit the password to level 0 (The lowest permission).
3. Used to set the password protection level of each function of the system.
4. Used to modify the user password;
5. Used to modify the maintenance password;

2.6.7 W) User Defined

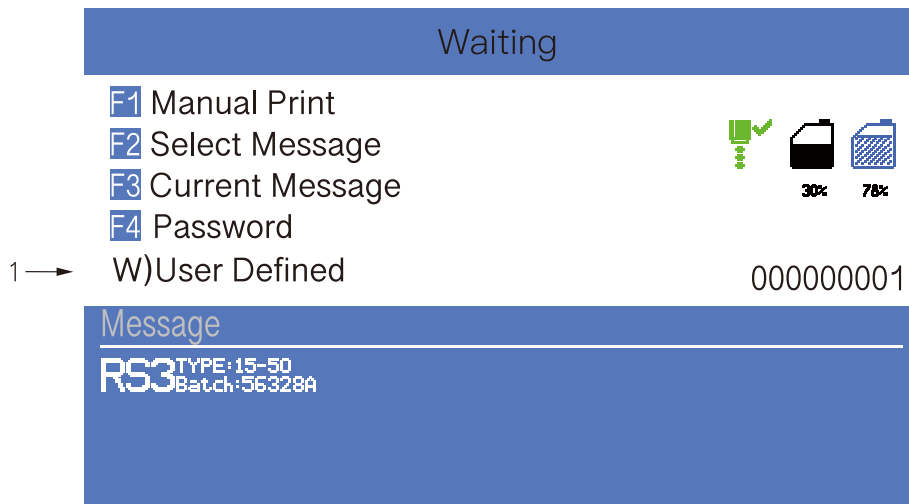

1. Users can customize frequently used functions to this area;

2.6.8 Photocell 1 Set

1) Photocell 1 Set	
1 →	Photocell 1 Level Low
2 →	Trigger Mode Trigger
3 →	Blocking Time 0
4 →	Photocell Mode Mode 1
5 →	Second Sensing Close
6 →	Signal Times 1
7 →	Effective 1

1. Select photocell 1 to be active by high or low level when triggering printing.
2. The way of the external photocell triggers printing, Gate or Trigger optional .
3. Within this time, the time interval between the trigger level and the trigger level can be obtained again (such as avoiding secondary sensing in the same product);
4. Select how to handle the photocell signal;
5. Open/Close the secondary sensing prompt;
6. Set the number of times the photocell is sensed before it is triggered effectively.
7. This option is associated with the sixth “Signal Times” setting, and the first few times within the set number of sensing times are valid;

2.6.9 Photocell 2 Set

2) Photocell 2 Set	
1 →	Photocell 2 Level Low
2 →	Photocell 2 FUC Disable
3 →	Trigger Mode Gate

1. Select photocell 2 to be active by high or low level when triggering printing.
2. Disable, Reset counter, Traversing print control , Reset traversing print , Opposite print and Reset detection & counting are optional.
3. The way of the external photocell triggers printing, Gate or Trigger are optional.

2.7 Specifications

Electrical specifications

Voltage	100V-240V AC
Frequency	50Hz-60Hz
Energy consumption	120(W) maximum value

Weight

Net weight	24KG
------------	------

Dimensions

Cabinet	345L * 286W * 570H
Printhead diameter	41mm
Printhead length	260mm
Nozzle size	70,60,50,40 μ m
Umbilical length	2700mm

Environment specifications

Operating temperature	5°C to 45°C
Ambient temperature replacing rate	10°C per hour at most
Relative humidity	0-90%, non-frosting
Storage temperature	5°C-45°C (original package)

3. Printer Operation

3.1 Commission (For F540/560/560Plus)

Printer needs to be filled with ink and exhaust air before use.

1. Open the lower cabin door, pull out the ink system, and fill 500-750ml of ink into the mixer tank with a beaker in the order of **A. B.* C. D.**, as shown in figure:

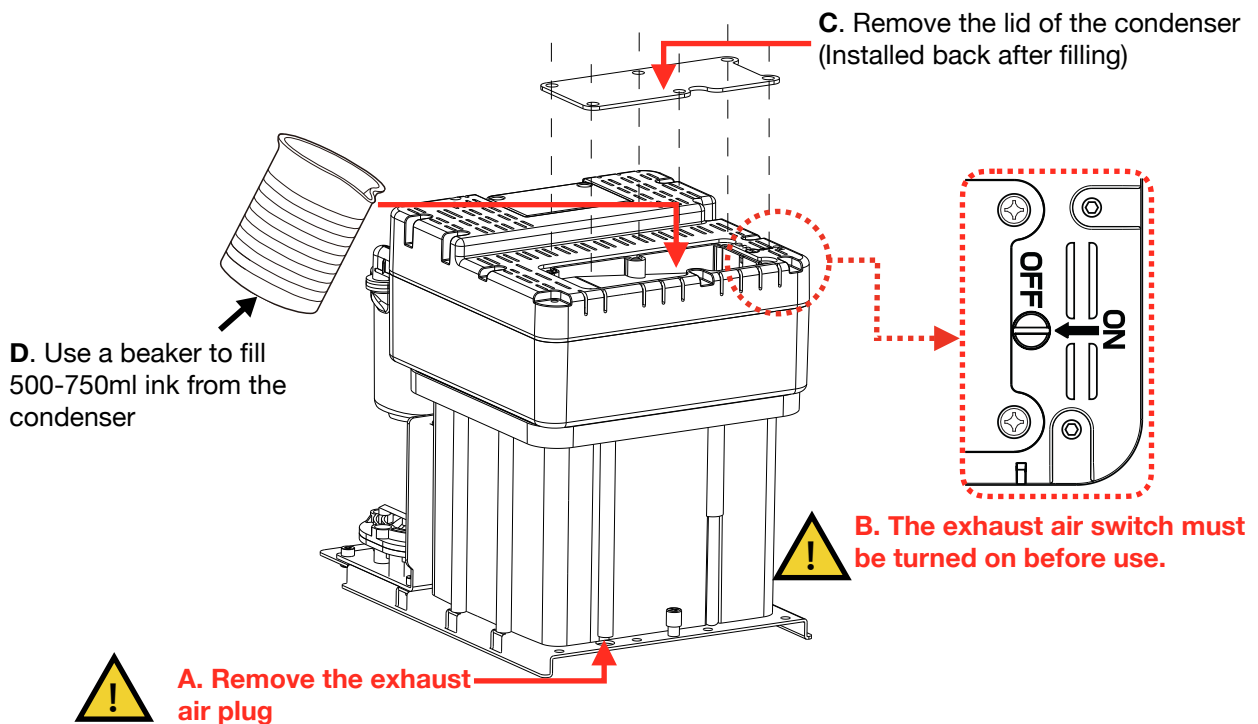

2. According to the label, install the correct ink and make-up cartridge to the correct position, push the ink system into the cabin and close the lower cabin door .
3. Connect the printer to an appropriate power source and power on the printer .
4. Enter the  **INKSYSTEM** menu and perform **E) Exhaust Air** program to complete ink way priming. Screen prompt will advise when complete. **NOTE: Ink will come from the gutter, place a catcher under the printhead.**
5. Clean the printhead.

* During normal use of the printer, the exhaust vent plug **A** needs to be removed, and the exhaust air switch **B** needs to be opened , otherwise it will cause printer failure.

3.2 Start The Printer

3.2.1 Start Jet

1. Connect the printer to an appropriate power source.
2. Open the printer head cover, check various components in the printhead, and check that various components are clean and dry.
3. Put on the printhead cover, press the power button at the right side of the printer, and wait for the screen to enter the main operation interface
4. Press  to start the program for about 4 minutes. The interface is as follows:

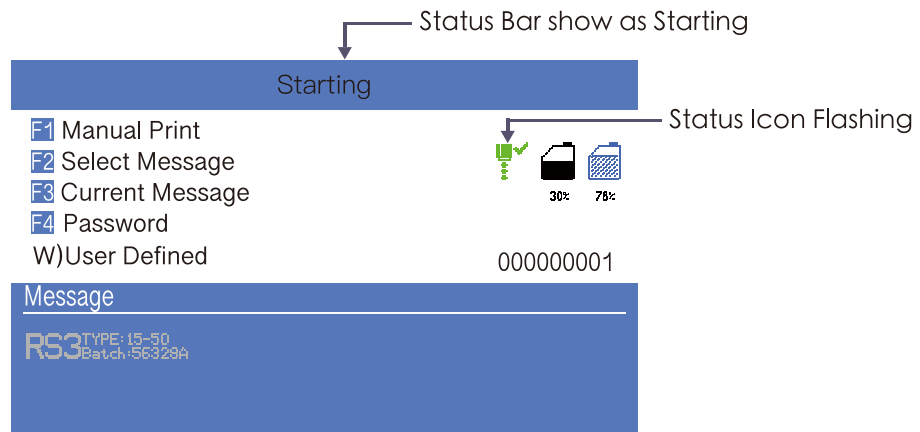

5. Observe the status indicator and the main screen. When the green LED is lit, the startup is completed. The interface is as follows:

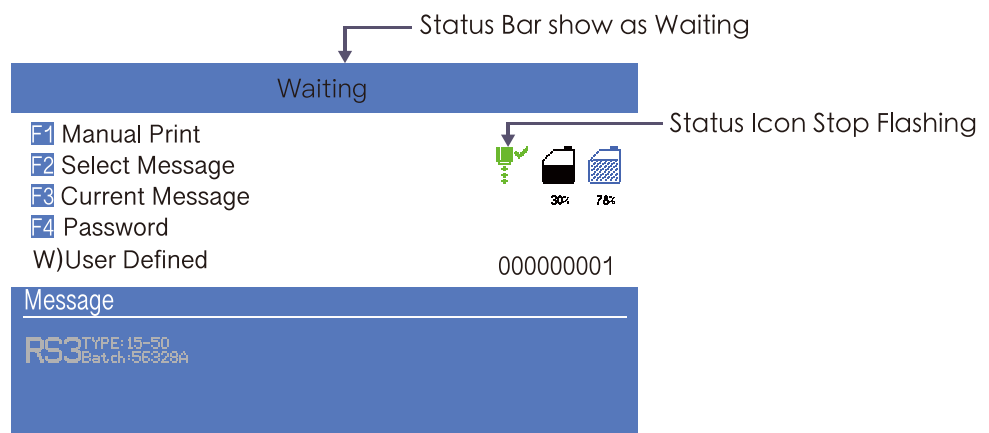

* Frequent start/stop jet will cause the ink to be diluted, which will affect the printing quality .

3.2.2 Inkjet Observation

Side View :

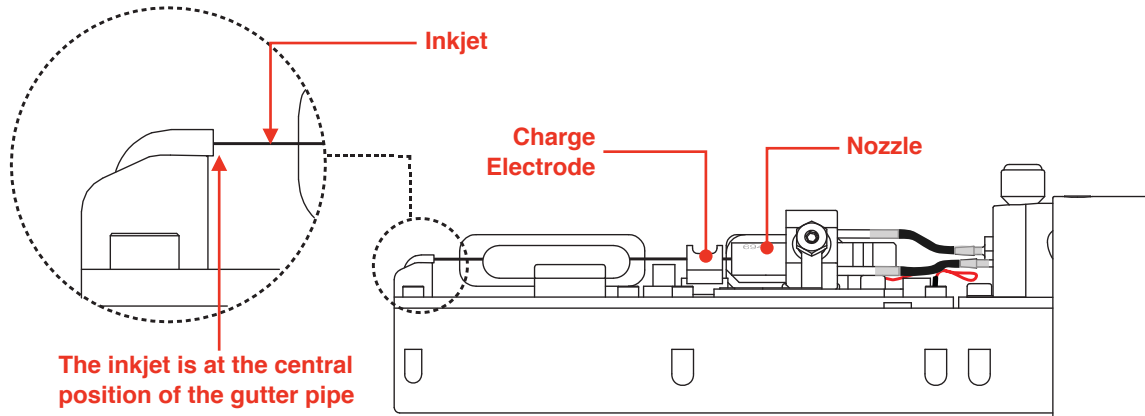

Front View :

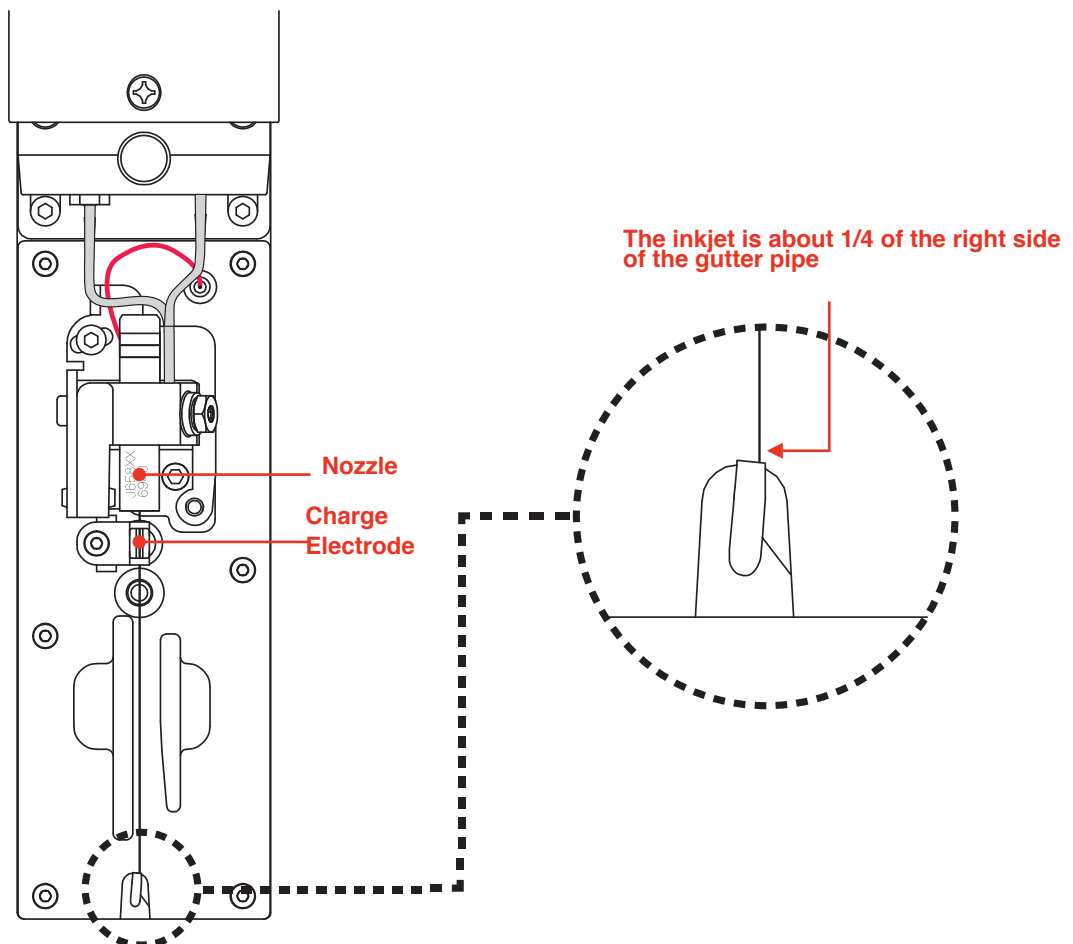

3.2.3 Drops Observation

The drops are generated after printer has started normally. It directly affects the printing effect and printing durability. Good drops roughly depend on the following three factors:

- Appropriate and stable pressure
- Correct ink viscosity
- Correct modulation value

The observation method is as follows:

1. Take out the magnifying glass in the standard and place it on the red LED light about 15mm.
2. Adjust the distance of the magnifying glass up and down slightly to observe the drops shown in the figure below:

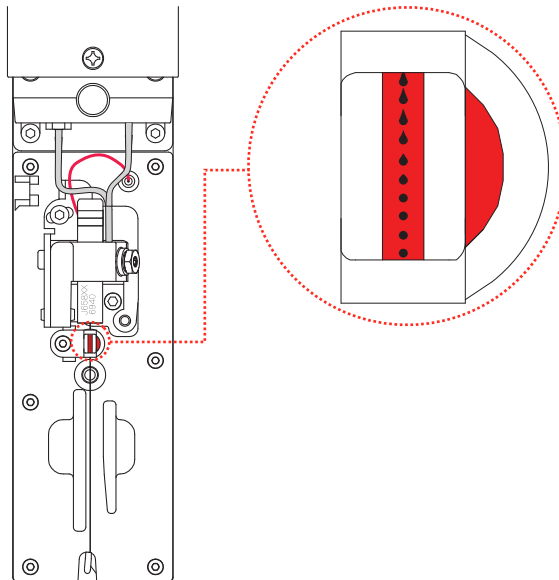

3. The drops are disconnected at the middle of the charge electrode. The shape of the drops before disconnection can refer to the following figure:

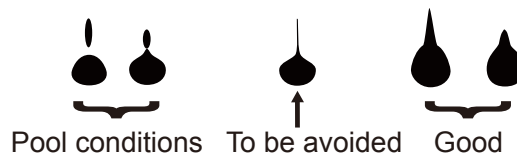

* The shape of drops can be adjusted through the "Modulation Set Level" in the **MACHINE SET** menu;

3.3 Stop Jet

3.3.1 Stop Jet and Clean

1. Press  button, it lasts for about 4 minutes, the interface is as follows:

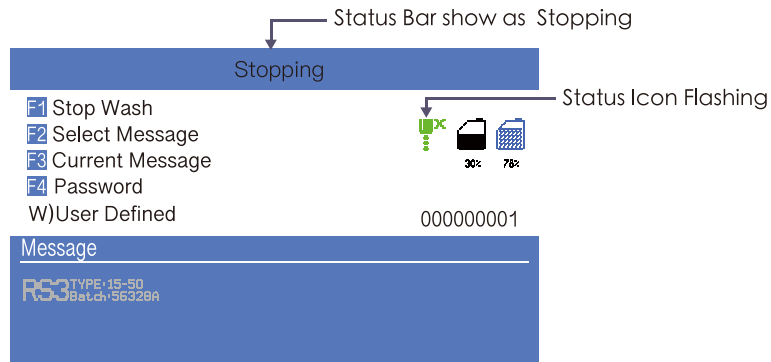

2. During cleaning after shutdown, remove the Printhead cover and observe if the printhead is dirty. If needed clean the printhead with the necessary cleaning agent.
3. Only after the interface is shown as below, the power can be turn off, Otherwise some of the tubes will be blocked, causing permanent damage.

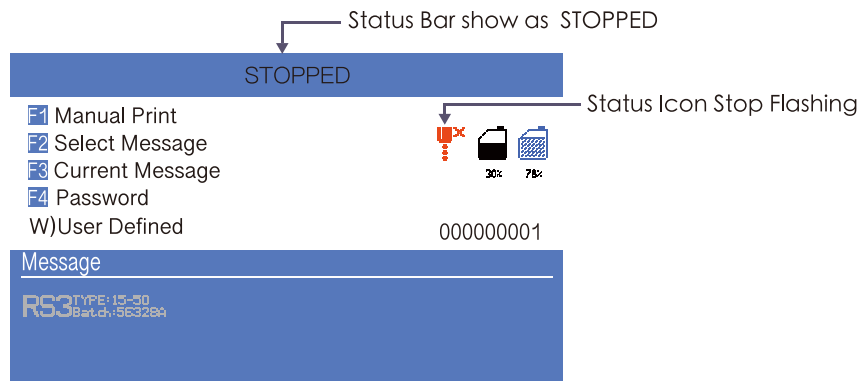

3.3.2 Stop and Clean (Power off during use of the printer)

If abnormal stop is caused due to power off, inkjet must be restarted at the earliest time after power on. It shall be normally cleaned and shut down after planned shutdown else some ink tubes of the printer may be blocked, causing permanent damage to the printer.

3.3.3 Stop and Clean (long-term stop of use)

Due to the quick-dry property of the ink, if long-term stop are needed, it's always suggested to drain the ink and clean the system. For details, check the section "4.6 Drain" and "4.7 Clean the ink system".

3.4 Create Message

3.4.1 Create a Sample Message

For example: Create the following message as follows with a file name "TEST" to create this message:

FastJet®

Follow these steps:

1. Enter the  PRINT DATA menu, select **E) Edit/Create Message - Create New Message**, confirm and enter the interface as shown in the following figure:

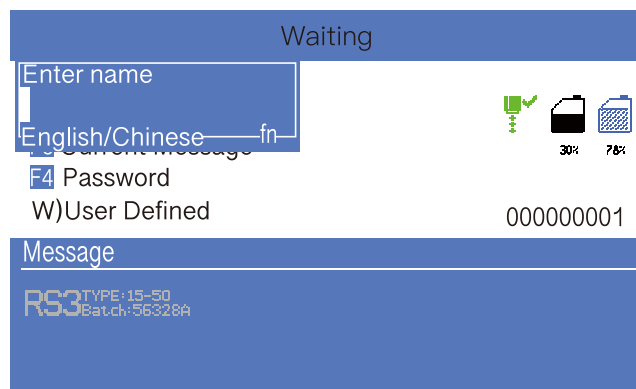

2. Input file name TEST, then press enter key, as shown in the following figure:

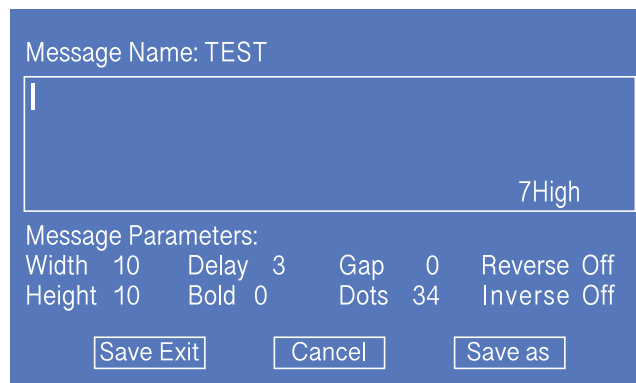

* Press the  button on this interface to pop up the Help window.

3. Press **F1** repeatedly. When the editing state is displayed as "16 High " then input "FastJet".

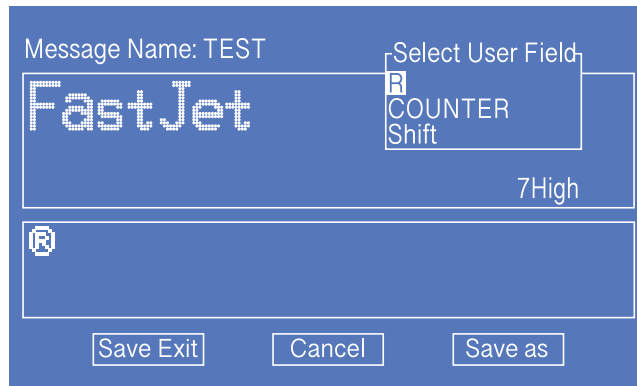

4. Press **F2** to select the “**R**” User Field (refer to 3.5.7 Logo), press the Enter key to insert, as shown below:





* In the editing interface, the **F2** function is “ Insert User Field ”.





5. After the content is entered, press  to switch to the “Save Exit” button and confirm.

Message Edit Additional Instructions:

- a.  +  key , move the cursor in units of one pixel.

- b.  +  key, move the cursor left and right in units of 100 pixels.

Bold, reverse, etc. for specific characters:

- a. In the editor , Press  to switch to the “Select” mode.
- b. Use  +  to select the characters you want to adjust.
- c. After selected , press  to adjust the property for the characters.
- d. After adjusted , press  to continue editing the normal content.

3.5 Create/Edit User Field

3.5.1 Time User Field

Follow the steps below to create :

1. Enter the  USER FIELD menu, select **E) Edit/Create User Field - N) New User Field**, as shown in the figure below:

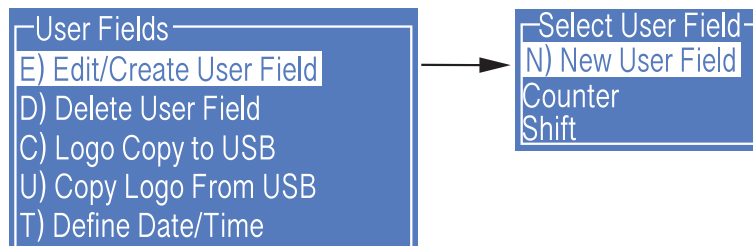

2. Input a file name, switch "**Attr**" to "**Time**" then confirm , as shown in the figure below:

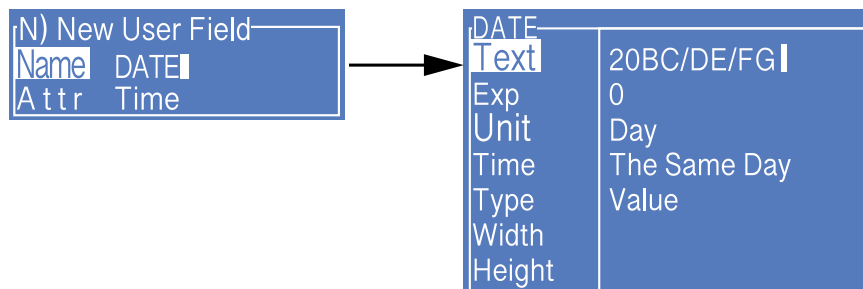

3. Fill the **Time Code*** in the "**Text**", and switch the "**Type**" to the type needed, if the printing result is digital numbers, just keep it as "**Value**".
4. Press Enter to complete, then press **F2** while editing the message to insert this field into the message.

* **Time Code** definition please refer to "3.5.2 Time User Field Additional instructions".

3.5.2 Additional remarks for time user field

Definition of Time User Field Code

Code	Definition
A	Monday to Sunday
BC	Year
DE	Month
FG	Day
HI	Hour
JK	Minute
LM	Second
OO	Week
PPP	Day
RR *	Alpha Year Code
SSS *	Alpha Month Code
T T *	Alpha Day Code
U U *	Alpha Hour Code
V V *	Alpha Minute Code

1. Actual printing date and time = system current time + number of days of Expiry term. If it is required to print the current time, the Expiry term is set as 0.
2. In the printing information, the time user field size is determined by the fonts selected during insertion.
3. When the "Print Form" is Data Matrix or QR Code, the "Width" and "Height" shall be set according to the standard. For details, see the section of preparation of QR code & bar code User Field.

3.5.3 Barcode User Field

The standards of barcode supported by the type include:

QR Code (Figure 1), Data Matrix (Figure 2), Code39 (Figure 3), Code128 (Figure 4), EAN8 (Figure 5), EAN13 (Figure 6), EAN128 (Figure 7), UPC-A(Figure 8)



Figure 1



Figure 2



Figure 3



Figure 4



Figure 5



Figure 6

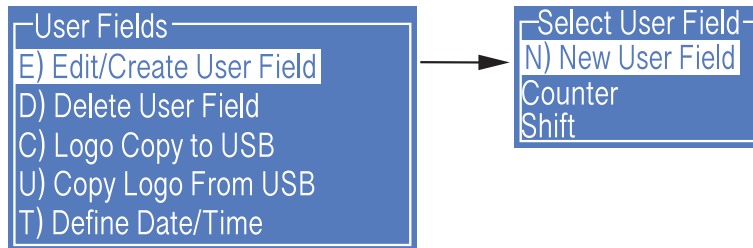

Figure 7

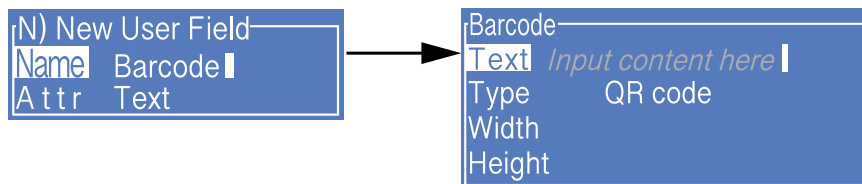

Figure 8

1. Enter the **USER FIELD** menu, select **E) Edit/Create User Field - N) New User Field**, as shown in the figure below:



2. Input a file name, switch **Attr** to **Text** then confirm , as shown in the figure below:



3. Fill the contents of Barcode to **Text** field, and switch the **Type** to the Barcode required.
4. When the **Type** is Data Matrix or QR Code, it is required to set the **Width** and **Height**.

3.5.4 Additional remarks for Barcode User Field

1. The size (Height x Width) supported by Data Matrix include 10x10, 12x12, 14x14, 16x16, 18x18, 20x20, 22x22, 24x24, 26x26, 32x32, 8x18, 8x32, 12x26, 16x36, 16x48.
2. The size (height x width) supported by QR Code include 21x21, 25x25, 29x29, 33x33.
3. If the prompt of "Unsupported size" or "Coding error" appears, please modify it to larger height and width for saving.
4. Code39 and Code128 are the Barcodes with variable length, EAN8 can code the character string with length of 7, and EAN13 can code the character string with length of 12.
5. UPC-A can encode 11 digits and the twelfth check digit is automatically generated.
6. The width of the Barcode is automatically generated with the printer, and the height is determined by the current font when the message is inserted in the User Field. It is not required for the user to adjust the "Width" and "Height".

3.5.5 Counter User Field

1. Enter the **USER FIELD** menu, select **E) Edit/Create User Field - N) New User Field**, as shown in the figure below:

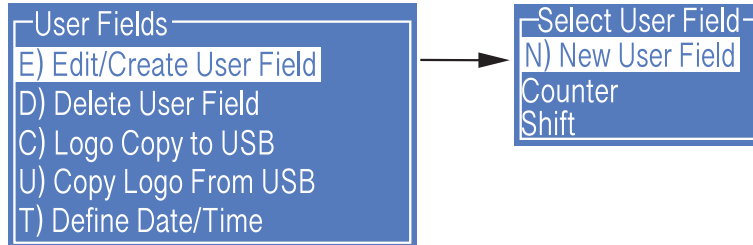

2. Input a file name, switch **Attr** to **Text** then confirm , as shown in the figure below:

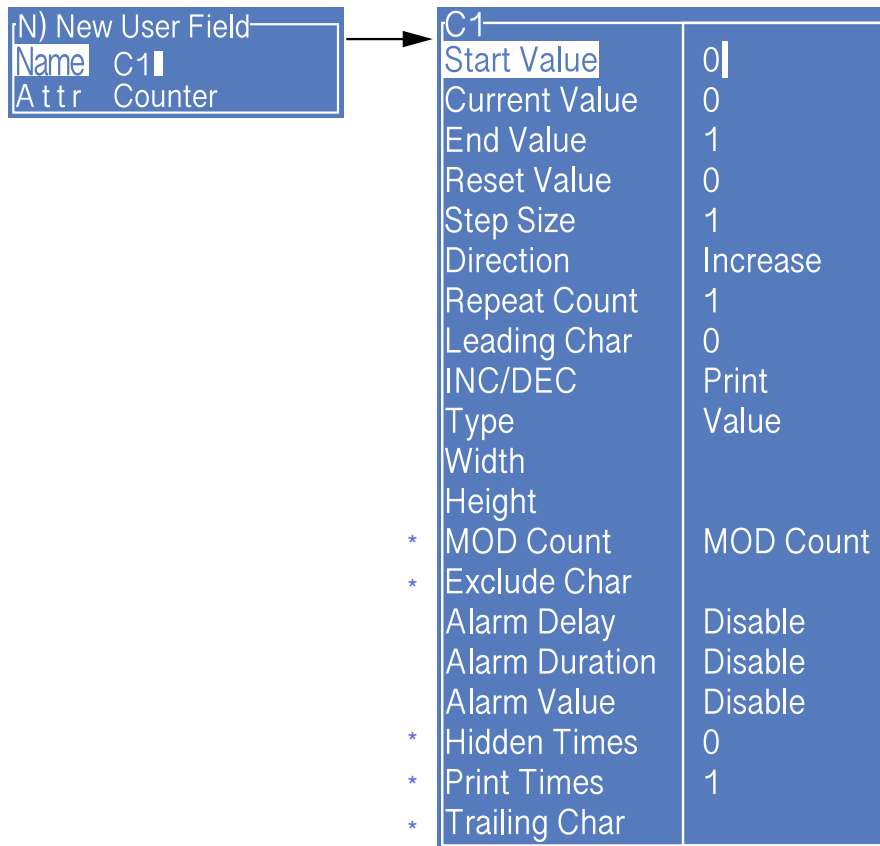

The Items with * mark available on F560/F560Plus only
 Instructions of each items refer to “ 3.5.6 Instructions for items in the Counter ”.

3.5.6 Instructions for Items in the Counter

1. **Start value** : Start value of the counter.
2. **End value** : End value of the counter
3. **Reset value** : Value to be reset when the function of "Reset Counter" of the Photocell 2 is used.
4. **Step size** : 1 at default, if set as 2, the counter will become "1, 3, 5, 7, ...".
5. **Direction** : Increase or decrease can be selected.
6. **Repeat Count** : 1 at default, printing times of each current value. For example, if set as 2, each counter will be printed for 2 times.
7. **Leading Char** : Leading character in front of the counter. For example, a counter range from 1 to 999, when the print counter is "1" and the leading character is "blank space", the printing result is "1". When the leading character is "0", the printing result will become "001".
8. **INC/DEC** : It is used for nesting use between all the counters in the printer.
9. **Type** : The counter can be converted to printing in special form, such as 1D barcode and 2D Barcode. For more details please refer to "3.5.4 Additional remarks for Barcode User Field".
10. **Mod Count** : 10, 16, 26, 32, 34, 36 optional.
11. **Exclude Char** : When 32 or 34 Mod is selected, 4 or 2 unprinted letters can be customized.
12. **Alarm Delay** : Set the delay of the counter alarm, available for system build-in "COUNTER" only
13. **Alarm Duration** : Set the duration of the counter alarm, available for system build-in "COUNTER" only
14. **Alarm Value** : Set the value of the counter alarm, which needs to be within the Start and End Value.
15. **Hidden Times** : Set the number of times this counter needs to be hidden in the message. The default value is "0", indicating that it is not hidden.
16. **Print Times** : Set the number of times this counter needs to be printed in the message. The default value is 1. For example, when the **Hidden Times** and the **Print Times** are 1, the print is performed once and disappears once.
17. **Trailing Char** : Set the suffix following the counter, the default is empty.

3.5.7 Logo User Field

The Logo User Field can create the customized logo of maximum 34 dots height (F540 only support 25 dots).

1. Enter the **USER FIELD** menu, select **E) Edit/Create User Field - N) New User Field**, as shown in the figure below:

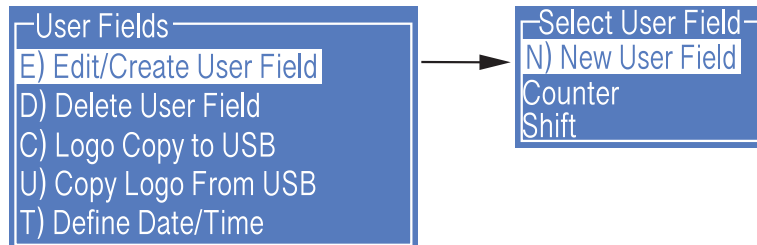

2. Input a file name, switch “Attr” to “Logo” then confirm , as shown in the figure below:

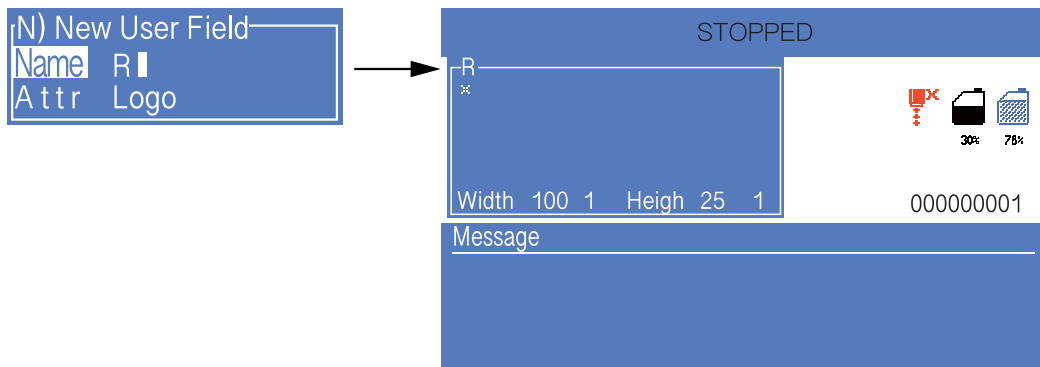

3. Operation instructions for logo are shown in the following table:

Key combination	Function
	Move the cursor by a dot
+	Move the cursor by a dot, and fill the dot
+	Move the cursor by a dot, and delete the dot
Space	Reverse the current dot, draw dot / delete dot

4. After drawing, press the "**F1**" key to set the logo size, as shown in the following figure:^①

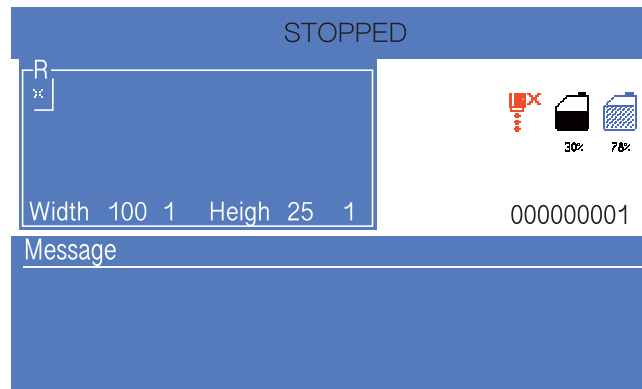

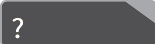

* Press the  button on this interface to pop up the Help window.

5. Complete logo size setting,^② press **Enter** to confirm the size, press **F2** to save and exit.
Then it can be called and printed.^③

Additional remarks for setting logo size:

1. The default canvas size is 100 dots wide and 25 dots high;

2. Use.  +  key to rapidly move the box for setting logo size;

3. In message editor , press **F2** can call the user fields list .

3.5.8 Code User Field

This function can integrate multiple User Fields (Clock, counter and text) in to generate a code.

1. Enter the **USER FIELD** menu, select **E) Edit/Create User Field - N) New User Field**, as shown in the figure below:

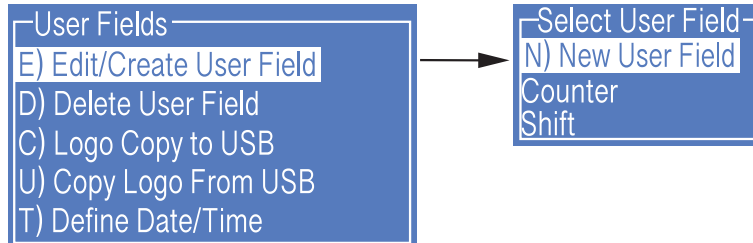

2. Input a file name, switch "**Attr**" to "**Code**" then press **Enter** to confirm , When the cursor hovers between Content 1 and Content 6, press **F2** to insert in sequence the User Fields to be combined. as shown in the figure below:

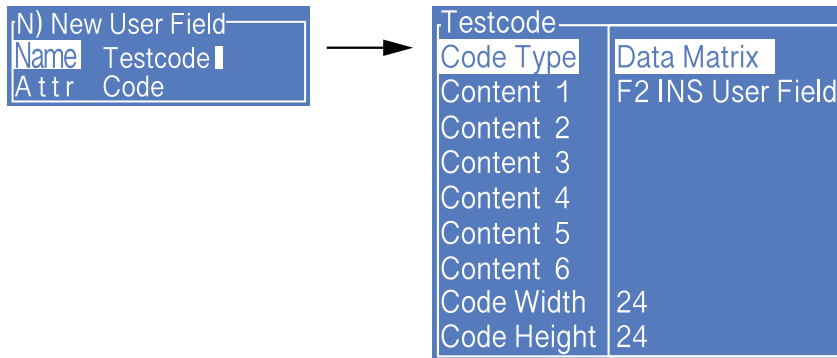

Note:

When the code type is selected as Data Matrix or QR code, the Barcode Width and Height shall be set. For more details please refer to " 3.5.4 Additional remarks for Barcode User Field "

3.5.9 External data User Field

The function can receive the external data predefined by the user and print them in sequence. The preparation steps are as follows:

1. Enter the **USER FIELD** menu, select **E) Edit/Create User Field - N) New User Field**, as shown in the figure below:

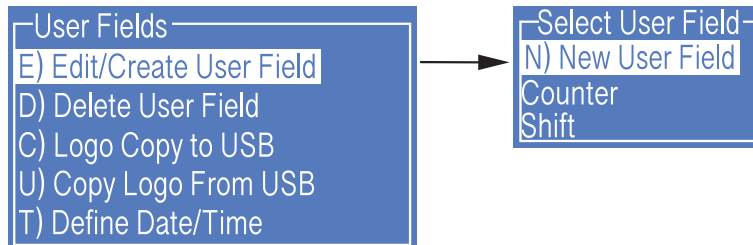

2. Input a file name, switch "**Attr**" to "**External Data**" then press **Enter** to confirm, as shown in the figure below:



Setting analysis:



- a. **Number of Char** : the bit of data transmitted from the computer to the ink jet printer.
- b. "**X0**" at the upper right corner of the external data editing interface is the identification code for communications with the external data User Field. Please correspond it with the setting of "User Field" in the computer software.
- c. When the **Type** is selected as Data Matrix or QR code, the Width and Height shall be set. For more details please refer to " 3.5.4 Additional remarks for Barcode User Field "

3.6 Message Parameters

3.6.1 Modify message parameters and contents

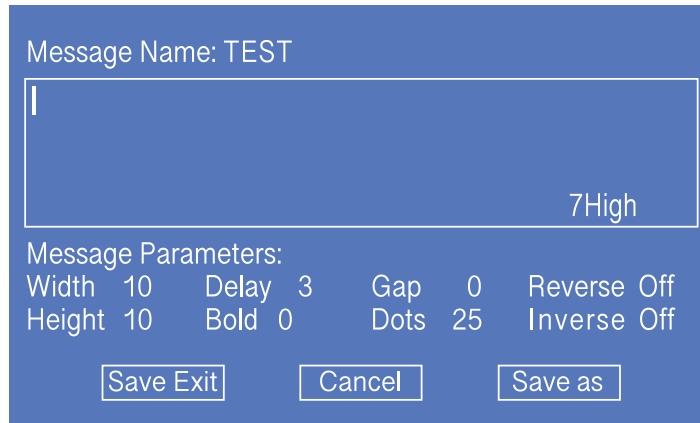
In the main screen, press the **F3** key to enter the interface to modify current message contents and parameters, as shown in the figure:

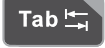

1. "WYSIWYG" information editing area;
2. Parameter editing area, through   to adjust parameters, width and delay parameters can be input directly.
3. File operation area.

* Tip : Press  key for cycle switching among three areas, and press the cursor key to move the cursor in the area.

More detail about **Message Parameters**, please read the following table:

Parameter	Range	Function
Width	1-255	Set information width, If the value is 1, the jet printing speed reaches the fastest speed under the current dots.
Height	1-10	The larger the value is, the higher character is.
Bold	0-7	Bold the current message
Delay	3-10000	Set product jet printing delay time. The larger the value is, the longer the time delay is.
Gap	0-8	The larger the value is, the larger the character spacing is.
Inverse	On / off	Adjust the character jet printing up / down direction
Reverse	On / off	Adjust the character jet printing left / right direction
Dots	5-34	The larger the value is, the slower the speed is, and the larger the number of dots to be printed is. The smaller the value is, the faster the speed is, and the smaller the number of dots to be printed is. F540 support 25 dots maximum .

3.7 Print Mode Setting

3.7.1 Single Printing Mode

The mode is commonly used for beer, beverage, food, daily necessities and other familiar industries . One trigger one printing.

1. Press **PRINT SET** button to enter the following setting interface:

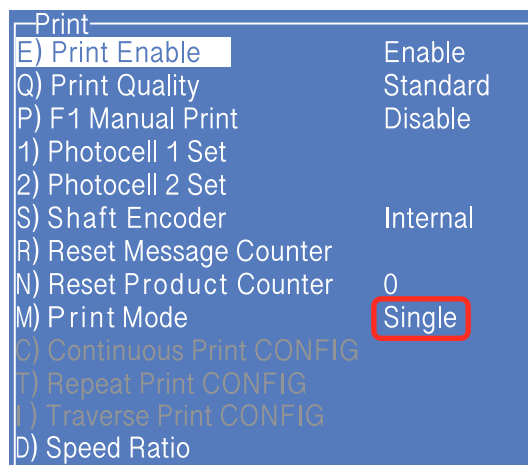

* The GRAY options indicate that the setting is invalid for the "Single Print" mode.

2. Switch the "Print Mode" to "Single" then the printer is in the single printing mode.
3. Other valid settings please refer to "2.6.3 PRINT SET Menu".

Note:

If you want to use a sensor to trigger products , the **P) F1 Manual Print** must be turn off.

3.7.2 Continuous Printing Mode

The mode is commonly used for building materials, pipe, steel material and other industries. The common feature is continuous processing, messages automatic interval printing.

1. Press **PRINT SET** button to enter the following setting interface:

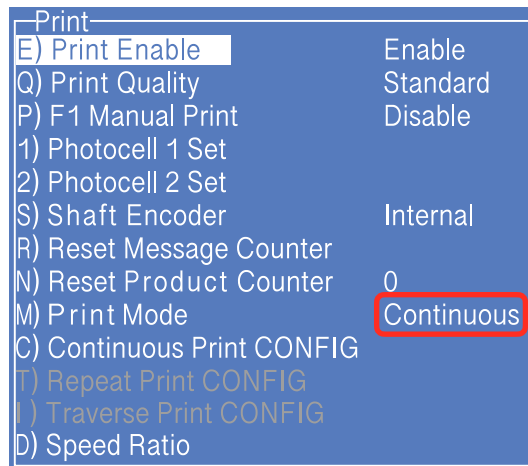

* The GRAY options indicate that the setting is invalid for the "Continuous Print" mode.

2. Switch the "Print Mode" to "Continuous" then the printer is in the continuous printing mode.
3. Enter " C) Continuous Print CONFIG " submenu, as shown in the following figure:

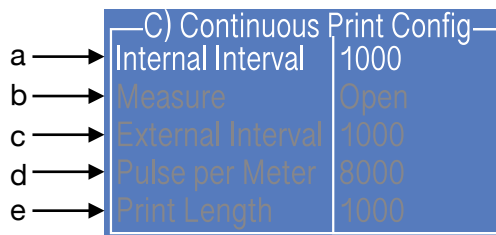

Setting analysis:

- a. The option sets the printing interval between each messages;
- Options b, c, d and e take effect after "Shaft Encode" was set as External.

4. Other valid settings please refer to "[2.6.3 PRINT SET](#)" .

3.7.3 Measure mode

The mode is commonly used in the wire cable, pipe and other industries requiring labelling of number of meters , the encoder must be used .

1. Press **PRINT SET** button to enter the following setting interface:

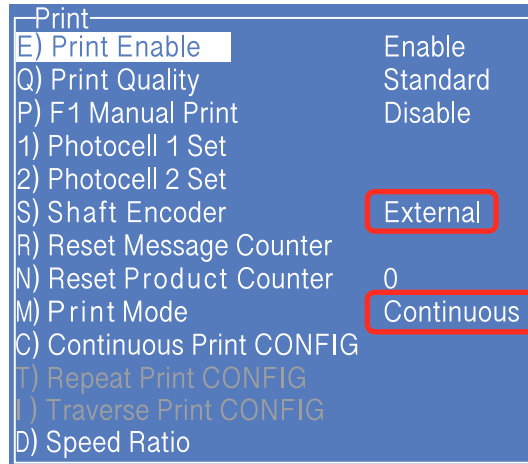

* The GRAY options indicate that the setting is invalid for the Measure Mode.

2. Select the "Shaft Encoder" as "external", and select "Print Mode" as "Continuous";
3. Enter " Continuous Print Configure " submenu, as shown in the following figure:

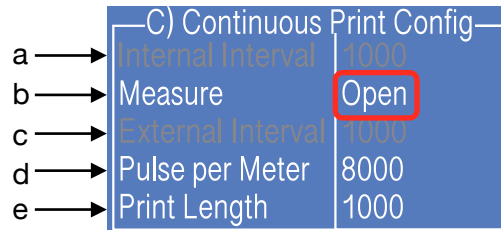

Setting analysis:

- a. The setting is invalid for the "Measure Print" mode.
 - b. Measure: The item shall be set as "Open"
 - c. The setting is invalid for the "Measure Print" mode.
 - d. For example, if the perimeter of the wheel is 250mm, the encoder with 2000 pulses then the value of pulse per meter is: $(1000 \div 250) \times 2000 = 8000$.
 - e. After the value of pulse per meter set, the length of each message interval within 1000mm can be set in this option.
4. Other valid settings please refer to "[2.6.3 PRINT SET Menu Analysis](#)".

3.7.4 Traverse Printing Mode

The mode is commonly used in electronics, label printing, egg and other industries, and provides highly-efficient production mode for the array type printing.

1. Press **PRINT SET** button to enter the following setting interface:

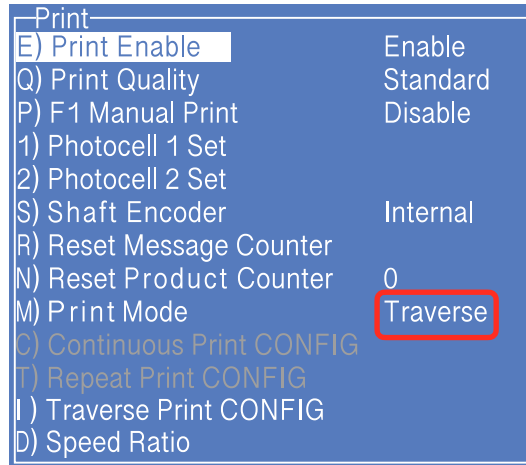

* The GRAY options indicate that the setting is invalid for the Traverse Mode.

2. Switch the "Print Mode" to "Traverse" then the printer is in the traverse printing mode.

3. Enter " **I) Traverse Print CONFIG** " submenu, as shown in the following figure:
The setting of the figure is the traverse printing mode achieved by only 1 sensor.

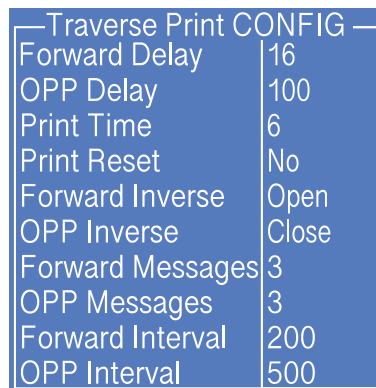

The printing effect is:

When the photocell obtains 1 signal, the printer will print 6 times, 3 of them are forward printings (each printing interval is 200), 3 times opposite printings (each printing interval is 500), the delay of the first printing is 16 and the delay of the fourth printing is 100.

If the printing sequence is disturbed, can try to use **Print Reset** to reset the forward and opposite printings.

3.7.5 Repeat Printing Mode

In this mode you can set the specific numbers of printing per trigger.

1. Press **PRINT SET** button to enter the following setting interface:

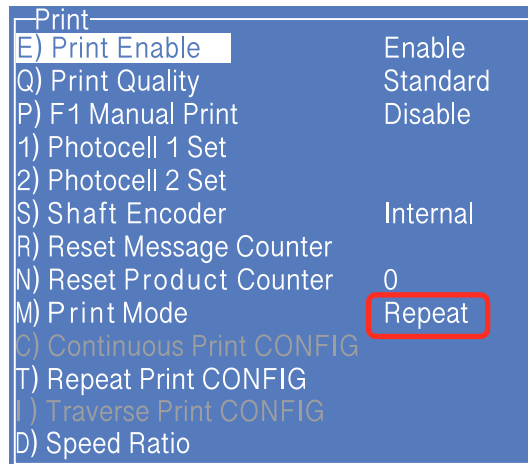

* The GRAY options indicate that the setting is invalid for the Repeat Mode.

2. Switch the "Print Mode" to "Repeat" then the printer is in the repeat printing mode.

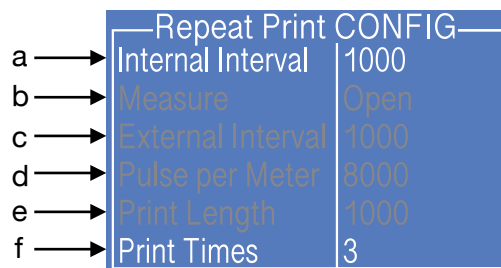

Setting analysis:

- a. The option sets the internal interval between each messages.

Options b. c. d. e. take effect after "Shaft Encoder" is set as "external".

- f. The option sets the printing times.

4. Other valid settings please refer to "[2.6.3 PRINT SET Menu Analysis](#)".

4. Maintenance

4.1 Diagnostic Screen







In any interface, press **i** button to enter the diagnosis screen, and the interface is as follows:

Ink Pressure	0bar	Temperature	20		
Temp: Cabinet	25	Head	35		
Phase: Angle	0	Profile	8		
Chamber: Low	ON	High	ON		
VMS: Set	42	Now	37		
Mix: OK	On	Low	On	High	Off
Detection:	Off	Time: 0	0		
Freq:	76kHz	Moduation:	40		













1. **Ink pressure** and **Ink Temperature**.
2. **Temp Cabinet**: Actual upper cabinet temperature.
Head : Heater temperature.
3. **Phase angle** and **Phase Profile** Value.
4. **Chamber** : VMS tank level status.
5. **VMS Set**: the optimum viscosity value calculated by the system according to ambient temperature and ink type.
Now: current actual viscosity of ink calculated by the Printer.
6. **Mix**: Level status of mixer tank, the normal status is OK: ON, :Low: ON, High; OFF.
7. **Detection**: Detection tank level status
Time: The time record for filling Detection tank with ink or makeup in seconds
8. **Freq** : The Frequency of the printer.
Modulation : The current modulation value.

4.2 Failure and warning icons

4.2.1 Failure icons

Icon	Name	Fault cause	Solution
	Mixing Tank Empty	Ink system leak	Check the leaking position. Please consult the service engineer
		The solvent components in the Mixer are vaporized after long-term storage of the printer	It is suggested to drain the old ink, and fill the new ink.
		Ink addition valve blocked	Remove and clean V2
	Charge Fault	Nozzle blockage	Clean the nozzle with nozzle flush and start it up again after drying
		Poor breakpoint	Conduct "breakpoint check", and adjust it to the optimum breakpoint position
		The Ink jet position is incorrect	Conduct "Jet alignment", and adjust it to the optimum position
		The ink is out of warranty period or is polluted	Drain the ink and replace with new ink
		Filter blocked	Clean ink system and replace the filter. For details, please consult the service engineer.
	Gutter Fault	The nozzle is blocked or miss aligned jet. Ink not entering the gutter	Clean the nozzle, clean print head, and start it up again after drying
		Long-term storage without correct stop procedure can cause blockage of the gutter pipe	Soak and clean the gutter pipe with solvent until it becomes unobstructed
	High-Voltage Leak	The print head has not been cleaned for a long time, causing excessive ink accumulating around the high-voltage deflection component	Clean the high voltage deflection component in the print head, thoroughly clean and dry it, and start it up again. If the failure is still not removed, consult the related service engineer.
	Solvent Chip Error	No solvent cartridge or inserting the wrong cartridge	Insert the certified solvent cartridge
	Ink Chip Error	No ink cartridge or inserting the wrong ink cartridge	Insert the certified ink cartridge

4.2.2 Warning icons

Icon	Name	Instructions for warning
	Jet printing operation	The ink in the system is circulating and in good condition, the printer is ready for printing
	Jet printing stop	The ink in the system is not circulating, the printer is in stopped state, and printing cannot be conducted
	Insufficient solvent	Solvent cartridge empty. Please replace with a new solvent cartridge
	Insufficient ink	Ink cartridge is empty. Please replace with the new ink Cartridge
	Print head cover open	The print head cover is opened, the printer cannot print. Fit the print head cover to enable printing
	Viscosity failure	Ink viscosity failure, indicates the ink is thick or thin. Please consult the related service engineer.
	Mixing tank full	The ink level in the mixer is high. Please consult the related service engineer.
	Encoder is too fast	The current print speed is too fast. Increase the character width or reduce the printing dot number
	Service	The ink jet printer needs maintenance. Please consult the related service engineer.
	Solvent level empty	The solvent in the solvent level is empty. Please consult the related service engineer.
	No enough time for phasing	Increase the print interval between each messages until it disappears
	VMS Chamber can not be empty	Please consult the related service engineer.
	VMS Chamber can not be full	Please consult the related service engineer.

4.3 Troubleshooting

- Turn on the power supply, there is no display on screen.

Reason	Solution
No voltage of the power supply	Check the power supply and related fuse

- Poor jet printing character quality or incomplete character

Reason	Solution
The printhead is too far from the product	Adjust the distance between the printhead and the printing surface
The character height is too small or too large	Reset the character height
The character width is too small or too large	Reset the character width
Wrong breakpoint shape	Observe and adjust the breakpoint. Refer to "3.2.3 How to Observe Break-up point".
Ink deposited on the gutter pipe	Clean the gutter pipe deposited with ink, check and adjust the ink position in the gutter. Refer to "3.2.2 Inkjet Observation".
The print varies in width and height	Determine the printing position again or select the rotary encoder

- No failure prompt but printing is not clear

Reason	Solution
Error in print width or wrong print on product position	Adjust the print width or printing delay
No print on product	Check sensor sensitivity

- Wrong or unstable Ink jet position

Reason	Solution
Nozzle blockage	Clean the nozzle. See "4.6 Nozzle cleaning".
Filter blockage	The trained operator can replace the filter under guidance of the service engineer.
Wrong ink jet position	Refer to "4.7 Ink jet adjustment".

4.4 Wash Nozzle

When the nozzle is blocked, manual cleaning is required for the function. The operation procedures are as follows:

1. Press **INK SYSTEM** , select and perform **F) Wash Nozzle** program.
2. After the program is started, manually clean the position shown in the following figure with cleaning agent.

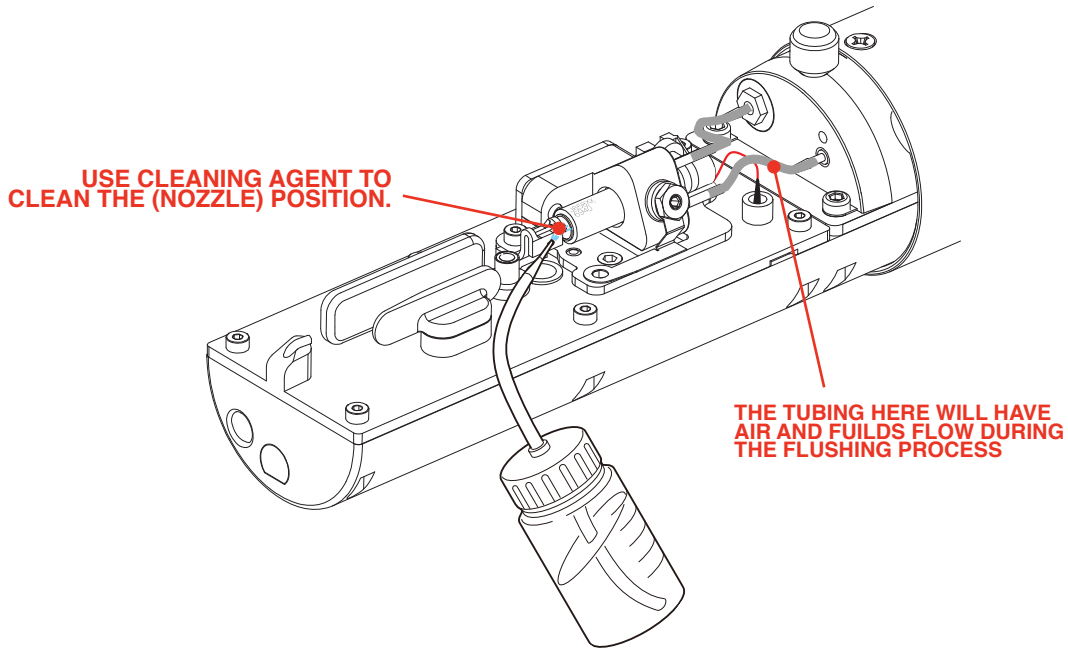

4.5 Ink Jet Alignment

Horizontal alignment : Slightly loosen the screw "A" and rotate the screw "B" slightly ,then the jet stream can be horizontal moved.

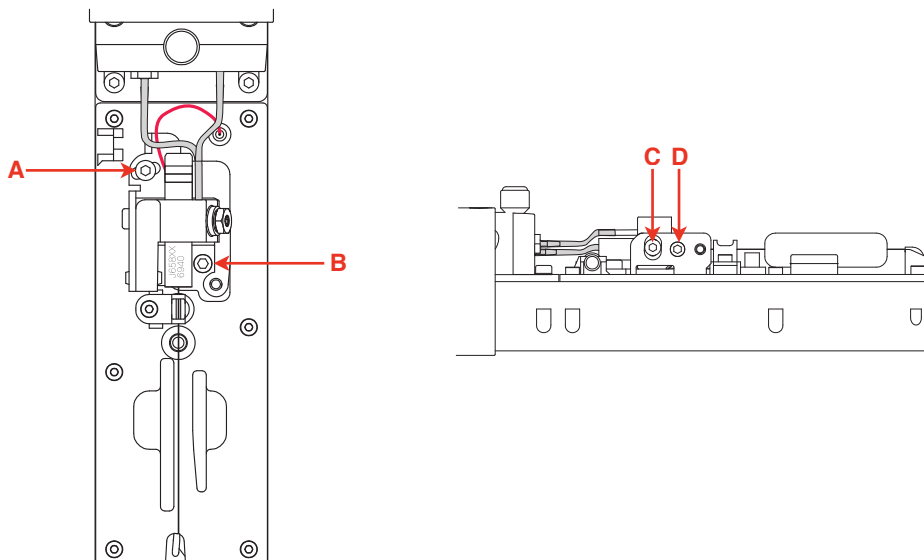

Vertical alignment : Loosen the screw "C" and rotate the screw "D" slightly ,then the jet stream can be vertical moved.

4.6 Drain(For F560Plus)

Press **INK SYSTEM** button , perform the **R) Drain** program ,finish the drain operation according to the system prompt.

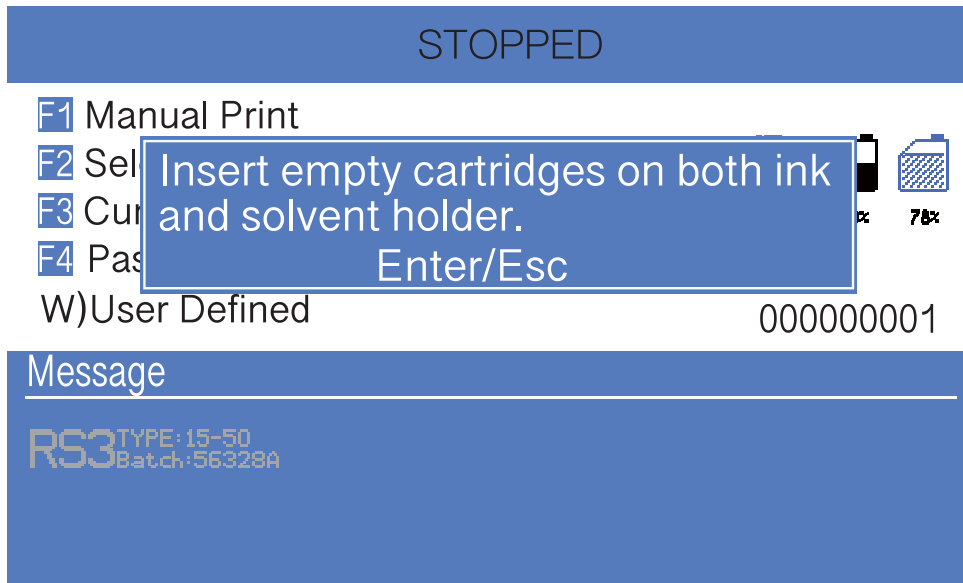

* The drain method of F540/F560 is different, more details please refer to the Official video or service manual

4.7 Clean Ink System

Press **INK SYSTEM** button , perform the **C) Clean Ink System** program ,finish the drain operation according to the system prompt.

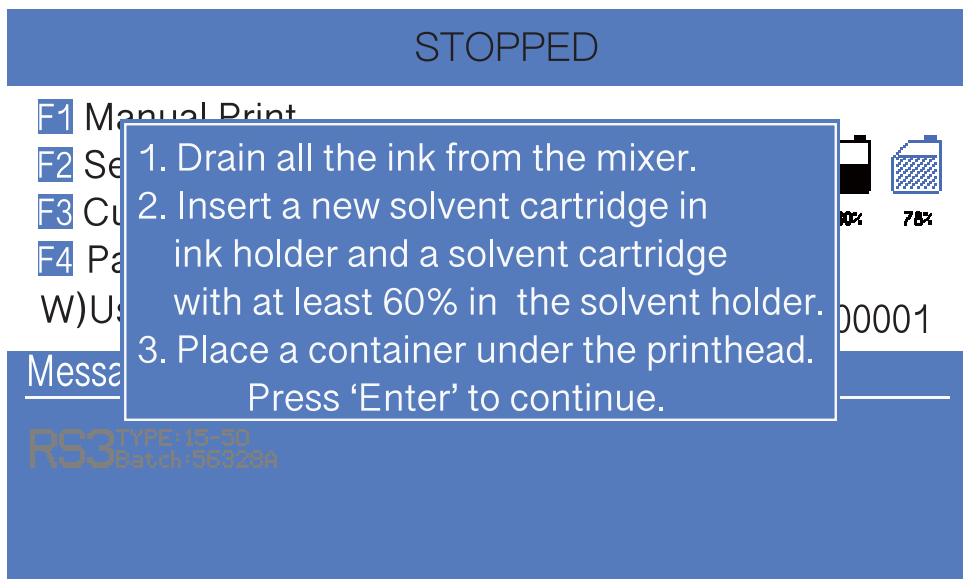

* The clean method of F540/F560 is different, more details please refer to the Official video or service manual, the figure above is for F540.

4.8 Sensor and Encoder Wiring Diagram

4.8.1 Sensor Diagram

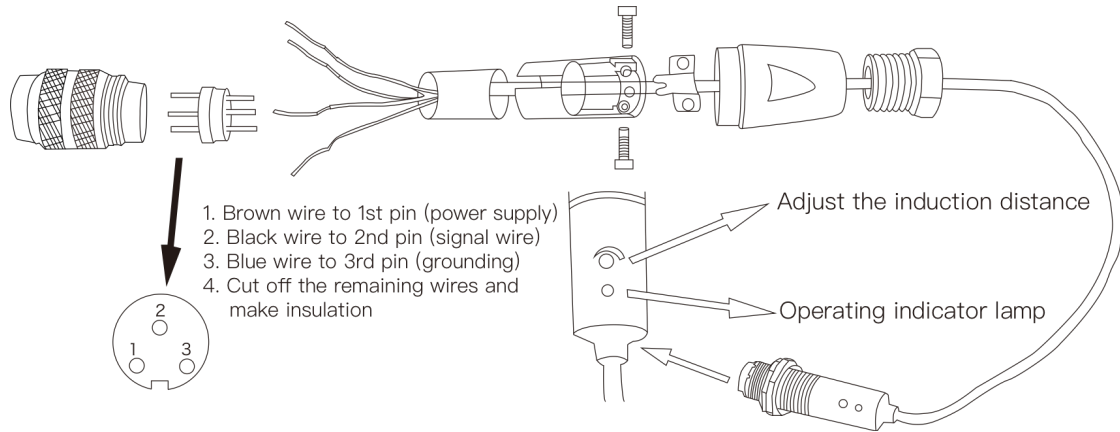

4.8.2 Encoder Diagram

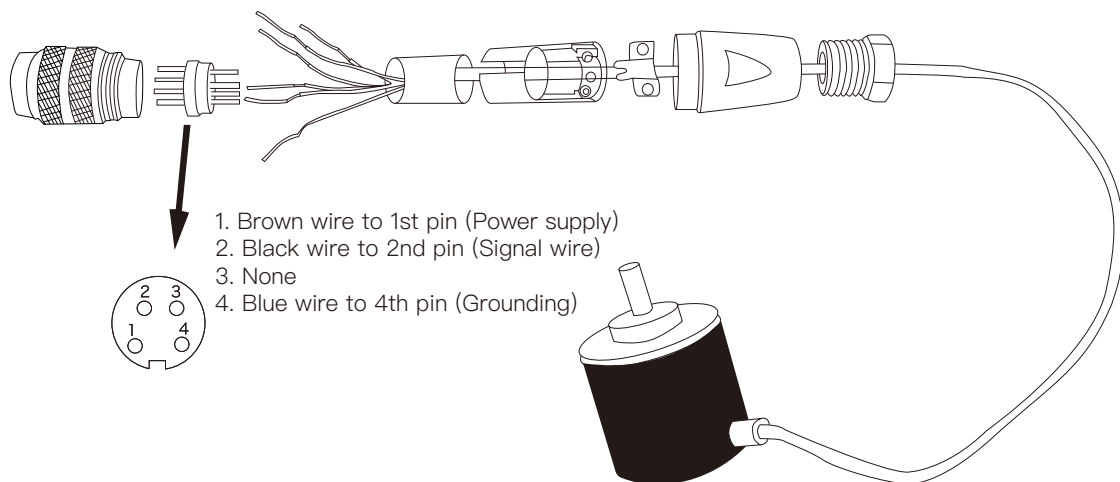

4.9 Printer Stander

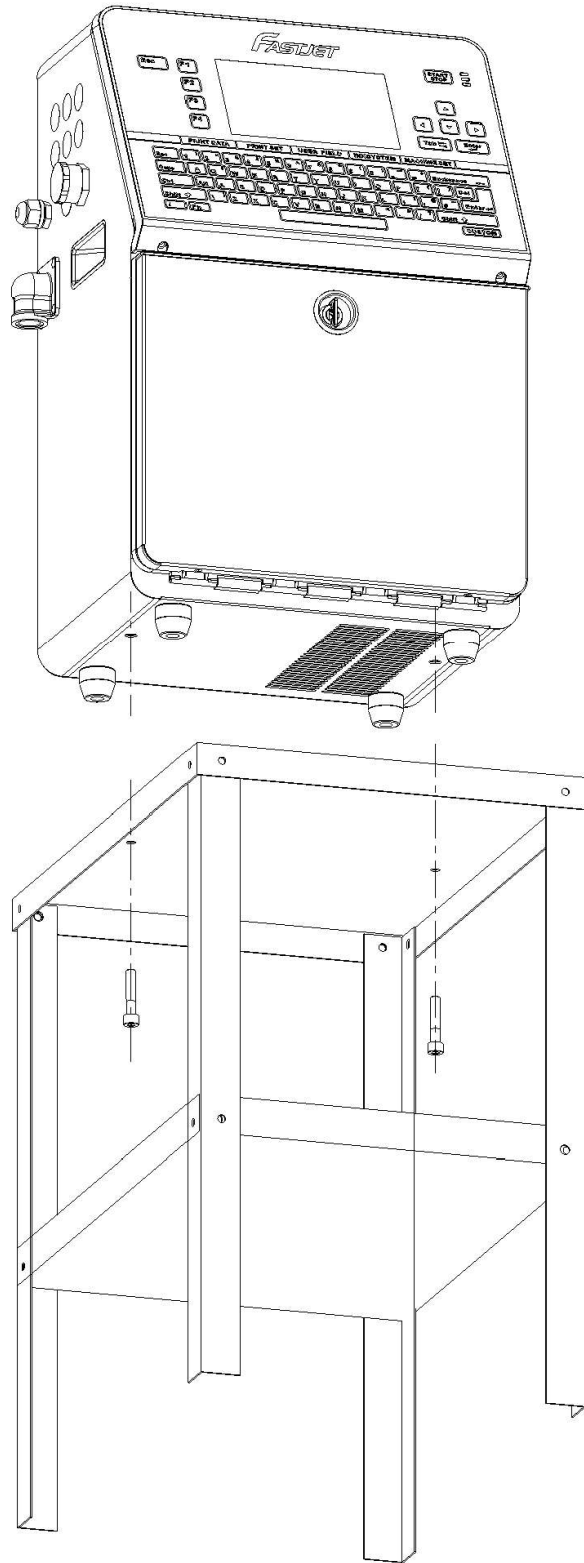

Fastjet reserves the right to modify the technical characteristics of the product without prior notice.

The logo for FASTJET, featuring the word "FASTJET" in a bold, italicized, red sans-serif font.

Manufacturer

Name: Shanghai Fastjet Electronic Equipment Co., Ltd.
Add.: No.18 Building, Lane 699, Zhangwenmiao Road,
Fengxian District, Shanghai

Tel: 00 86 21-57484418
Fax: 00 86 21-57484498
<http://www.fast-jet.com>